

Gross Power  
178 HP at 2,000 rpm

Net Power  
163 HP at 2,000 rpm

Bucket Capacity  
0.60 ~ 1.50m<sup>3</sup>

Operating Weight  
25,200 kg

# Robex R260LC-9S

With Tier 2 Engine installed



## ▲ HYUNDAI CONSTRUCTION EQUIPMENT

Head Office(Sales Office)

3F, Bundang First Tower, 55 Bundang-ro, Bundang-gu, Seongnam-si, Gyeonggi-do, 13591, Korea

PLEASE CONTACT

# PRIDE AT WORK

Robex 260LC-95

Hyundai Heavy Industries strives to build state-of-the-art earthmoving equipment to give every operator maximum performance, more precision, versatile machine preferences, and proven quality. Take pride in your work with Hyundai!

## Machine Walk-Around

### Engine Technology

Easy & Simple Serviceability / Auto engine warm up feature / Anti-restart feature

### Hydraulic System Improvements

New patented hydraulic control for improved controllability / Improved control valve design for added efficiency and smoother operation / New auto boom and swing priority system for optimum speed / New auto power boost feature for additional power when needed / Improved arm-in and boom-down flow regeneration system for added speed and efficiency

### Pump Compartment

Industry-leading, powerful, reliable Kawasaki designed, variable volume in-line axial piston pumps  
New compact solenoid block equipped with 4 solenoid valves, 1 EPPR valve, 1 check valve accumulator and pilot filter - controls 2 speed travel, power boost, boom priority, safety lock

### Enhanced Operator Cab

#### Improved Visibility

Enlarged cab with improved visibility  
Larger right-side glass, now one piece, for better right visibility  
Safety glass windows on all sides - less expensive than polycarbonate and won't scratch or fade  
Closeable sunshade for operator convenience / Reduced front window seam for improved operator view

#### Improved Cab Construction

New steel tube construction for added operator safety, protection and durability  
New window open/close mechanism designed with cable and spring lift assist and single latch release

#### Improved Suspension Seat / Console Assembly

Ergonomic joysticks with auxiliary control buttons for attachment use - now with new sleek styling  
Adjustable arm rests - turn dial to raise or lower for optimum comfort

#### Advanced 7" Color Cluster

New Color LCD Display with easy to read digital gauges for hydraulic oil temperature, water temperature, and fuel / Simplified design makes adjustment and diagnostics easier. Also, new enhanced features such as rear-view camera are integrated into monitor.(OPT)  
3 power modes : (P) Power, (S) Standard, (E) Economy, 2 work modes : Dig & Attachment, (U) User mode for operator preference  
Enhanced self-diagnostic features with GPS / satellite technology  
One pump flow or two pump flow for optional attachment is now selectable through the cluster.  
/ New anti-theft system with password capability  
Boom speed and arm regeneration are selectable through the monitor.  
Auto power boost is now available - selectable (on/off) through the monitor.  
Powerful air conditioning and heat with auto climate control, 20% more heat and air output than 7 series!  
RMS (Remote Management System) works through GPS/satellite technology to ultimately provide better customer service and support.(OPT)

### Undercarriage

Sealed track chain (urethane seals) / Standard track rail guard / Comfortable bolt-on steps  
Large upper roller cut-outs for debris clean-out / Tapered side frames for debris clean-out / Grease-type track tensioner



### Operator Comfort

In 9S Series cabin you can easily adjust the seat, console and armrest settings to best suit your personal operating preferences. Seat and console position can be set together and independent from each other. Other preference settings that add to overall operator comfort include the fully automatic high capacity airconditioning system and the radio / USB player.



### Reduced Stress

Work is stressful enough. Your work environment should be stress free. Hyundai's 9S Series provides improved cab amenities, additional space and a comfortable seat to minimize stress to the operator. A powerful climate control system provides the operator with optimum air temperature. An advanced audio system with USB player, AM/FM stereo is perfect for listening to music favorites.



### Operator - Friendly Cluster

The advanced new cluster with 7 inch wide color LCD screen and toggle switch allows the operator to select his personal machine preferences. Power and work mode selection, self diagnostics, optional rear-view camera, maintenance check lists, start-up machine security, and video functions were integrated into the cluster to make the machine more versatile and the operator more productive.



### Wide Cabin with Excellent Visibility

The newly designed cabin was conceived for more space, a wider field of view and operator comfort. Special attention was given to a clear, open and convenient interior with plenty of visibility on the machine surroundings and the job at hand. This well balanced combination of precision aspects put the operator in the perfect position to work safely and securely.



# PREFERENCE

Operating a 9S Series is unique to every operator. Operators can fully customize their work environment and operating preferences to fit their individual needs.



## Computer Aided Power

The engine horsepower and hydraulic horsepower together in unison through the advanced CAPO(Computer Aided Power Optimization) system, flow for the job at hand. Operator can set their own preferences for boom or swing priority, power mode selection and optional work tools at the touch of a button. The CAPO system also provides complete self diagnostic features and digital gauges for important information like hydraulic oil temperature, water temperatures and fuel level. This system interfaces with multiple sensors placed throughout the hydraulic system as well as hydraulic flow.

## Power Mode

P (Power Max) mode maximizes machine speed and power for mass production. S (Standard) mode provides a reduced, fixed rpm for optimum performance and improved fuel economy. For maximum fuel savings and improved control, E (Economy) mode provides precise flow based on load demand. Three unique power modes provide the operator with custom power, speed and fuel economy.

## Work Mode

The work mode allows the operator to select single flow attachments like a hydraulic breaker or bi-directional flow attachments like a crusher. Flow settings unique to each attachment can be programmed from within the cluster.

## User Mode

Some jobs require more precise machine settings. Using the versatile U (User) mode, the operator can customize engine speed, pump output, idle speed and other machine settings for the job at hand.



## Improved Hydraulic System

To achieve optimum precision, Hyundai redesigned the hydraulic system to provide the operator with super fine touch and improved controllability. Improved pump flow control reduces flow when controls are not being used to minimize fuel consumption.

Improved spool valves in the control valve are engineered to provide more precise flow to each function with less effort.

Improved hydraulic valves, precision-designed variable volume piston pumps, fine-touch pilot controls, and enhanced travel functions make any operator running a 9S Series look like a smooth operator. Newly improved features include arm-in and boom-down flow regeneration, improved control valve technology and innovative auto boom and swing priority for optimal performance in any application.



## Auto Boom-swing Priority

This smart function automatically and continuously looks the ideal hydraulic flow balance for the boom and swing motions of the machine. The advanced CAPO system monitors the hydraulic system and adjusts its settings to maximize performance and productivity.



# PRECISION

Innovative hydraulic system technologies make the 9 series excavator fast, smooth and easy to control.





# PERFORMANCE

9S Series is designed for maximum performance to keep the operator working productively.

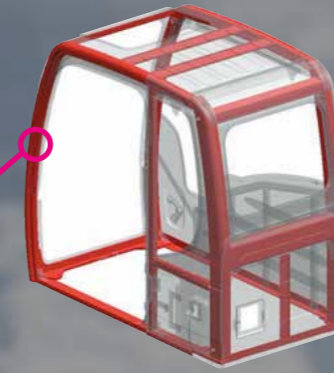
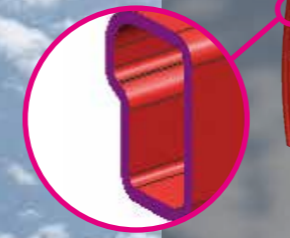

## Structure Strength

The 9S Series cabin structure has been fitted with stronger but slimmer tubing for more safety and improved visibility. Low-stress, high strength steel is integrally welded to form a stronger, more durable upper and lower frame. Structural integrity was tested by way of FEM (Finite Elements Method) analysis and long-term durability tests.

## Track Rail Guard & Adjusters

Durable track rail guards keep track links in place. Track adjustment is made easy with standard grease cylinder track adjusters and shock absorbing springs.



## HYUNDAI HM5.9 ENGINE

The six cylinders, turbo-charged, 4 cycle, charger air cooled engine is built for power, reliability, economy and low emissions.

## A More Reliable Way To Reach Your Dream.

The HYUNDAI HM5.9 engine has been designed with 40% fewer parts than the competition. That means there's less that can go wrong when you need it most. It also means fewer parts to inventory.

Repairs are simplified because no special tools are needed for maintenance. The weight of the machine is reduced without sacrificing strength.

The HYUNDAI HM5.9 engine is capable of reaching emission standards without electronic engine controls. You get a proven power plant that meets ecological concerns, without paying a premium for technology you don't need.



\* Photo may include optional equipment.



# PROFITABILITY

9S Series is designed to maximize profitability through improved efficiencies, enhanced service features and longer life components.



# Hi-MATE

Option

## IT'S CONVENIENT, EASY AND VALUABLE

Hi-MATE Hyundai's newly developed remote management system, utilizes GPS-satellite technology to provide customers with the highest level of service and product support available. Hi-MATE enables users to remotely evaluate machine performance, access diagnostic information, and verify machine locations at the touch of a button.

## WHAT IS BENEFITS



### Increase Productivity

It helps you operate machines in efficient. You can check the difference between total engine hours and actual working hours. See how productive your machines are and plan any required cost saving solutions. Hi-MATE offers working information such as working / idling hours, fuel consumption and rate.



### Convenient and Easy Monitoring

There is nothing much to do to monitor your machines. Just log on to the Hi-MATE website or mobile application. Hi-MATE allows you to watch your machines whenever and wherever you are.



### Security

Protect your machines from theft or unauthorized usage with Hi-MATE. If the machine moves out of the Geo-fence boundary, you will get alerts.

## Long-Life Components

9S series excavators were designed with bushings designed for long-life lube intervals (250 hrs) & polymer shims (wear resistant, noise reducing), long-life hydraulic filters (1,000hrs), long-life hydraulic oil (5,000hrs), more efficient cooling systems and integrated preheating systems which extend service intervals, minimize operating costs and reduce machine down time.



## Fuel Efficiency

9S Series excavators are engineered to be extremely fuel efficient. New innovations like two-stage auto decel system and the new economy mode help to conserve fuel and reduce the impact on the environment.



## Easy Access

Ground-line access to filters, lube fittings, fuses, machine computer components and wide open compartments makes service more convenient on the 9S Series.



# SPECIFICATIONS

## ENGINE

maker / Model	HYUNDAI HM5.9		
Type	Water-cooled, 4-cycle Diesel, 6-Cylinder in-line, Direct injection, Turbo charged, Charger air cooled, Low emission		
Rated flywheel horse power	SAE	J1995(gross)	178 HP / 2,000 rpm
		J1349 (net)	163 HP / 2,000 rpm
DIN		6271/1 (gross)	180 PS / 2,000 rpm
		6271/1 (net)	165 PS / 2,000 rpm
Max. torque	72.2 kgf.m / 1,500 rpm		
Bore X stroke	102 x 120 mm		
Piston displacement	5,880cc		
Batteries	2 X 12V X 160 AH		
Starting motor	24V, 4.5 kW		
Alternator	24V, 90 Amp		

## HYDRAULIC SYSTEM

### MAIN PUMP

Type	Variable displacement tandem-axis piston pumps
Max. flow	2 X 228 L / min
Sub-pump for pilot circuit	Gear pump
Cross-sensing and fuel saving pump system	

### HYDRAULIC MOTORS

Travel	Two-speed axial pistons motor with brake valve and parking brake
Swing	Axial piston motor with automatic brake

### RELIEF VALVE SETTING

Implement circuits	350 kgf/cm <sup>2</sup>
Travel	350 kgf/cm <sup>2</sup>
Power boost (boom, arm, bucket)	380 kgf/cm <sup>2</sup>
Swing circuit	300 kgf/cm <sup>2</sup>
Pilot circuit	40 kgf/cm <sup>2</sup>
Service valve	Installed

### HYDRAULIC CYLINDERS

No. of cylinder bore X stroke	Boom: 2-135 X 1,345 mm
	Arm: 1-145 X 1,620 mm
	Bucket: 1-130 X 1,185 mm

## DRIVES & BRAKES

Drive method	Fully hydrostatic type
Drive motor	Axial piston motor, in-shoe design
Reduction system	Planetary reduction gear
Max. drawbar pull	21,600 kgf
Max. travel speed (high / low)	5.8 km/hr / 3.4 km/hr
Gradeability	35° (70 %)
Parking brake	Multi wet disc

## CONTROL

Pilot pressure operated joysticks and pedals with detachable lever provide almost effortless and fatigueless operation.	
Pilot control	Two joysticks with one safety lever (LH): Swing and arm, (RH): Boom and bucket (ISO)
Traveling and steering	Two levers with pedals
Engine throttle	Electric, Dial type

## SWING SYSTEM

Swing motor	Fixed displacement axial pistons motor
Swing reduction	Planetary gear reduction
Swing bearing lubrication	Grease-bathed
Swing brake	Multi wet disc
Swing speed	12.5 rpm

## COOLANT & LUBRICANT CAPACITY

Re-filling	liter
Fuel tank	400.0
Engine coolant	35.0
Engine oil	24.0
Swing device - gear oil	6.0(7)
Final drive (each) - gear oil	3.3(4.5)
Hydraulic system (including tank)	285.0
Hydraulic tank	165.0

## UNDERCARRIAGE

The X-leg type center frame is integrally welded with reinforced box-section track frames. The undercarriage includes lubricated rollers, idlers, track adjusters with shock absorbing springs and sprockets, and a track chain with double or triple grouser shoes.

Center frame	X - leg type
Track frame	Pentagonal box type
No. of shoes on each side	51 EA
No. of carrier rollers on each side	2 EA
No. of track rollers on each side	9 EA
No. of rail guards on each side	2 EA

## OPERATING WEIGHT (APPROXIMATE)

Operating weight, including 5,850mm boom, 3,050mm arm, SAE heaped 1.08m<sup>3</sup> bucket, lubricant, coolant, full fuel tank, full hydraulic tank, and all standard equipments.

### MAJOR COMPONENT WEIGHT

Upperstructure	5,520 kg
Boom (with arm cylinder)	2,460 kg
Arm (with bucket cylinder)	1,540 kg

### OPERATING WEIGHT

Shoes		Operating weight	Ground pressure
Type	Width mm	kg	kgf/cm <sup>2</sup>
Triple grouser	600 mm	R260LC-9S	25,200
		R260LC-9S H/W	27,450
	700 mm	R260LC-9S	25,500
		R260LC-9S H/W	28,020
	800 mm	R260LC-9S	25,800
		R260LC-9S H/W	28,400
900 mm	R260LC-9S	26,100	
	Double grouser	700 mm	R260LC-9S H/W

## AIR CONDITIONING SYSTEM

The air condition system for the machine contains the fluorinated greenhouse gas with global warming potential of R134a. ( Global Warming Potential : 1430 )  
The system hold 0.8kg refrigerant consisting of a CO2 equivalent 1.14kg metric tonne.  
For more information, Please refer to the manual.

# DIMENSIONS & WORKING RANGE

## R260LC-9S / R260NLC-9S DIMENSIONS

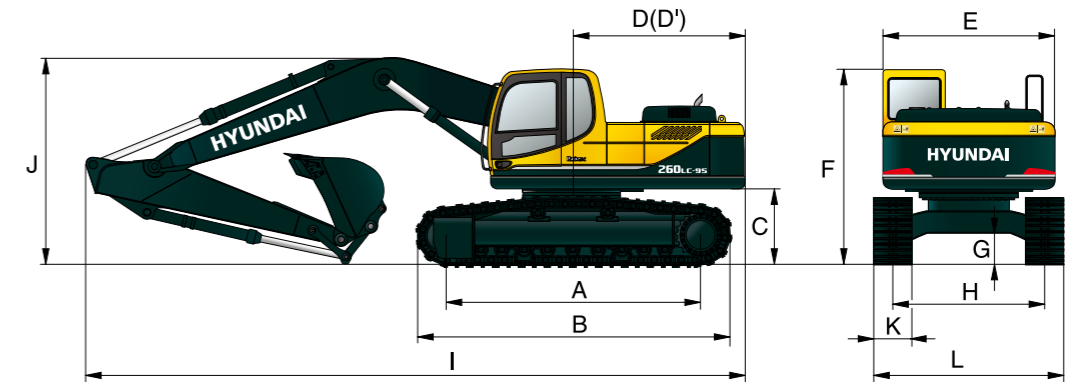

Unit : mm (ft - in)

A Tumbler distance	R260LC-9S	3,830
	R260NLC-9S	3,830
B Overall length of crawler		4,640
C Ground clearance of counterweight		1,115
D Tail swing radius		2,975
D' Rear-end length		2,870
E Overall width of upperstructure		2,840
F Overall height of cab		2,990
G Min. ground clearance		480
H Track gauge	R260LC-9S	2,580
	R260NLC-9S	2,380

Boom length	5,850			
Arm length	2,100	2,500	3,050	3,600
I Overall length	10,050	10,000	9,920	9,910
J Overall height of boom	3,530	3,590	3,220	3,590
K Track shoe width	600	700	800	900
L Overall width	R260LC-9S	3,180	3,280	3,380
	R260NLC-9S	2,980	-	-

## R260LC-9S / R260NLC-9S WORKING RANGE

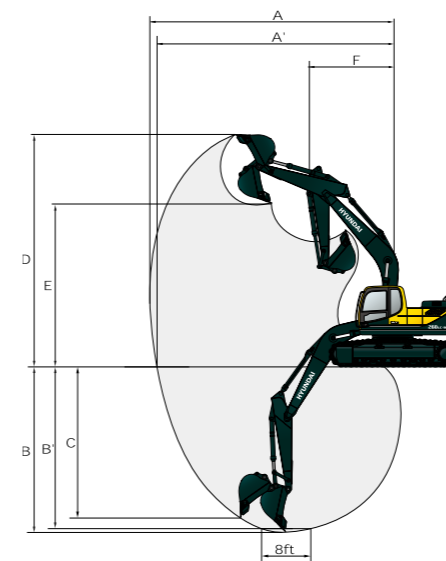

Unit : mm (ft - in)

Boom length	5,850			
Arm length	2,100	2,500	3,050	3,600
A Max. digging reach	9,550	9,870	10,360	10,870
A' Max. digging reach on ground	9,360	9,680	10,190	10,700
B Max. digging depth	6,050	6,450	7,000	7,550
B' Max. digging depth (8' level)	5,840	6,260	6,830	7,400
C Max. vertical wall digging depth	5,480	5,640	6,150	6,830
D Max. digging height	9,450	9,460	9,670	9,920
E Max. dumping height	6,360	6,420	6,630	6,860
F Min. swing radius	4,420	4,200	3,980	3,900

# DIMENSIONS & WORKING RANGE

## R260LC-9S HIGH WALKER DIMENSIONS

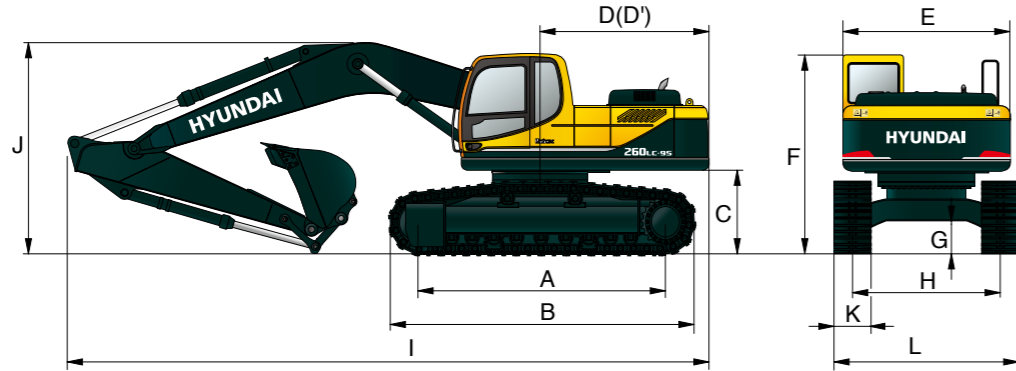

Unit : mm (ft - in)

A	Tumbler distance	4,030
B	Overall length of crawler	4,940
C	Ground clearance of counterweight	1,470
D	Tail swing radius	2,975
D'	Rear-end length	2,870
E	Overall width of upperstructure	2,840
F	Overall height of cab	3,345
G	Min. ground clearance	765
H	Track gauge	2,790

Boom length	5,850			
Arm length	2,100	2,500	3,050	3,600
I Overall length	10,060	9,970	9,760	9,930
J Overall height of boom	3,610	3,750	3,240	3,620
K Track shoe width	Type	Triple grouser		
	Width	600t	700	800
L Overall width	3,180	3,280	3,380	3,480

## R260LC-9S HIGH WALKER WORKING RANGE

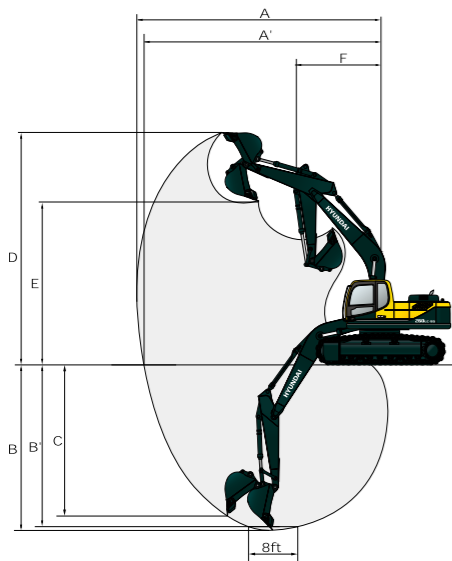

Unit : mm (ft - in)

Boom length	5,850			
Arm length	2,100	2,500	3,050	3,600
A Max. digging reach	9,550	9,870	10,360	10,870
A' Max. digging reach on ground	9,280	9,160	10,110	1,360
B Max. digging depth	5,680	6,080	6,630	7,180
B' Max. digging depth (8' level)	5,470	5,890	6,460	7,030
C Max. vertical wall digging depth	5,120	5,300	5,790	6,470
D Max. digging height	9,820	9,840	10,040	10,280
E Max. dumping height	6,730	6,790	7,000	7,220
F Min. swing radius	4,140	4,030	3,940	3,900

# LIFTING CAPACITY

Rating over-front Rating over-side or 360 degree

## R260LC-9S

Boom : 5.85m / Arm : 2.10 m / Bucket : 1.08 m<sup>3</sup> SAE heaped / Shoe : 600mm triple grouser

Load point height (m)		Load radius								At max. reach		
		3.0 m		4.5 m		6.0 m		7.5 m		Capacity		Reach
												m
6.0 m	kg					*5,790	*5,790			5,220	3,200	8.32
4.5 m	kg			*7,810	*7,810	*6,510	5,570	*6,000	3,690	4,520	2,710	8.91
3.0 m	kg			*10,260	8,200	*7,600	5,190	5,900	3,550	4,210	2,480	9.17
1.5 m	kg			*12,300	7,520	8,250	4,850	5,720	3,380	4,170	2,430	9.14
Ground	kg			13,110	7,250	8,010	4,640	5,600	3,270	4,410	2,580	8.80
-1.5 m	kg	*15,460	15,160	13,090	7,230	7,940	4,580			5,060	2,990	8.13
-3.0 m	kg	*17,100	15,470	*12,090	7,390	8,050	4,680			*6,290	3,980	6.98
-4.5 m	kg	*13,360	*13,360	*9,460	7,790							

Boom : 5.85m / Arm : 2.50 m / Bucket : 1.08 m<sup>3</sup> SAE heaped / Shoe : 600mm triple grouser

Load point height (m)		Load radius								At max. reach					
		1.5 m		3.0 m		4.5 m		6.0 m		7.5 m		Capacity		Reach	
														m	
6.0 m	kg												4,900	3,000	8.67
4.5 m	kg						*6,070	5,670	*5,630	3,770	4,280	2,550	9.23		
3.0 m	kg					*9,550	8,410	*7,210	5,280	5,950	3,590	3,990	2,340	9.48	
1.5 m	kg					*11,790	7,650	8,310	4,910	5,750	3,410	3,950	2,290	9.45	
Ground	kg					*12,990	7,280	8,030	4,660	5,600	3,270	4,150	2,410	9.13	
-1.5 m	kg			*15,100	14,960	13,050	7,190	7,910	4,560	5,550	3,220	4,690	2,750	8.49	
-3.0 m	kg	*16,360	*16,360	*18,120	15,250	*12,470	7,300	7,970	4,610			5,940	3,550	7.41	
-4.5 m	kg			*14,860	*14,860	*10,430	7,620								

Boom : 5.85m / Arm : 3.05 m / Bucket : 1.08 m<sup>3</sup> SAE heaped / Shoe : 600mm triple grouser

Load point height (m)		Load radius								At max. reach				
		1.5 m		3.0 m		4.5 m		6.0 m		7.5 m		Capacity		Reach
														m
6.0 m	kg									*3,700	*3,700	4,400	2,660	9.22
4.5 m	kg						*5,350	*5,350	*5,060	3,830	3,880	2,280	9.74	
3.0 m	kg			*13,640	*13,640	*8,400	*8,400	*6,540	5,360	*5,660	3,620	3,630	2,090	9.98
1.5 m	kg			*9,450	*9,450	*10,870	7,800	*7,820	4,950	5,750	3,400	3,580	2,040	9.95
Ground	kg			*10,570	*10,570	*12,490	7,280	8,010	4,640	5,560	3,230	3,730	2,130	9.65
-1.5 m	kg	*9,940	*9,940	*13,870	*13,870	12,930	7,090	7,830	4,480	5,460	3,140	4,150	2,390	9.05
-3.0 m	kg	*13,540	*13,540	*18,430	14,860	*12,780	7,110	7,820	4,470			5,080	2,980	8.06
-4.5 m	kg	*17,830	*17,830	*16,580	15,340	*11,360	7,340	8,020	4,640			*5,940	4,480	6.48

Boom : 5.85m / Arm : 3.60 m / Bucket : 1.08 m<sup>3</sup> SAE heaped / Shoe : 600mm triple grouser

Load point height (m)		Load radius										At max. reach				
		1.5 m		3.0 m		4.5 m		6.0 m		7.5 m		9.0 m		Capacity		Reach
																m
6.0 m	kg									*3,930	*3,930			3,960	2,360	9.77
4.5 m	kg									*4,530	3,890	*2,500	*2,500	3,530	2,040	10.27
3.0 m	kg							*5,890	5,490	*5,190	3,670	*3,590	2,550	3,310	1,870	10.49
1.5 m	kg			*12,610	*12,610	*9,960	8,040	*7,260	5,040	5,790	3,430	4,210	2,430	3,260	1,820	10.46
Ground	kg			*11,020	*11,020	*11,930	7,390	8,070	4,680	5,570	3,230	4,090	2,320	3,380	1,890	10.18
-1.5 m	kg	*9,010	*9,010	*13,200	*13,200	*12,900	7,090	7,830	4,470	5,430	3,100			3,710	2,100	9.62
-3.0 m	kg	*12,120	*12,120	*16,820	14,680	12,880	7,040	7,750	4,400	5,390	3,070			4,420	2,550	8.71
-4.5 m	kg	*15,830	*15,830	*17,940	15,050	*12,020	7,180	7,850	4,490					*5,790	3,580	7.30

1 | Lifting capacity is based on SAE J1097, ISO 10567.

2 | Lifting capacity of the Robex Series does not exceed 75% of the tipping load with the machine on firm, level ground or 87% of full hydraulic capacity.

3 | The load point is a hook located on the back of the bucket.

4 | (\*) indicates the load limited by hydraulic capacity.





# BUCKET SELECTION GUIDE & DIGGING FORCE

## BUCKETS

All buckets are welded with high-strength steel.



SAE heaped  
m<sup>3</sup>

0.60  
0.79

1.03

1.08  
1.27  
1.50

◆ 1.07 ◆ 1.27  
◆ 1.15 ◆ 1.46

◎ 1.16

Capacity m <sup>3</sup>		Width mm		Weight kg	Recommendation mm			
SAE heaped	CECE heaped	Without side cutters	With side cutters		5,850 Boom			
					2,100 Arm	2,500 Arm	3,050 Arm	3,600 Arm
0.60	0.55	760	880	720	●	●	●	●
0.79	0.70	890	1,010	790	●	●	●	●
1.03	0.90	1090	1,210	890	●	●	●	■
1.08	0.95	1,130	1,250	910	●	●	●	■
1.27	1.10	1,290	1,410	1,010	●	■	■	▲
1.50	1.30	1,490	1,610	1,080	●	■	▲	-
◆1.07	0.95	1,150	-	1,120	●	●	■	▲
◆1.15	1.00	1,210	-	1,160	●	●	■	▲
◆1.27	1.10	1,310	-	1,240	●	■	▲	-
◆1.46	1.28	1,460	-	1,320	■	▲	▲	-
◎1.16	1.00	1,340	-	1,280	●	■	▲	-

◆ Heavy duty bucket

◎ Rock-Heavy duty bucket

●: Applicable for materials with density of 2,000 kg /m<sup>3</sup> or less

■: Applicable for materials with density of 1,600 kg /m<sup>3</sup> or less

▲: Applicable for materials with density of 1,100 kg /m<sup>3</sup> or less

## ATTACHMENT

Booms and arms are welded with a low-stress, full-box section design. 5.85m Boom and 2.1m, 2.5m, 3.05m & 3.6m Arms are available.

## DIGGING FORCE

Boom	Length	mm	5,850				Remark
	Weight	kg	2,460				
Arm	Length	mm	2,100	2,500	3,050	3,600	[ ]: Power Boost
	Weight	kg	1,420	1,450	1,540	1,600	
Bucket digging force	SAE	kN	156.9 [170.4]	156.9 [170.4]	156.9 [170.4]	156.9 [170.4]	[ ]: Power Boost
	IOS	kN	178.5 [193.8]	178.5 [193.8]	178.5 [193.8]	178.5 [193.8]	
Arm crowd force	SAE	kN	134.4 [145.9]	130.4 [141.6]	114.7 [124.6]	104.0 [112.9]	[ ]: Power Boost
	IOS	kN	139.3 [151.2]	134.4 [145.9]	118.7 [128.8]	107.9 [117.1]	

Note: Boom weight includes arm cylinder, piping, and pin  
Arm weight includes bucket cylinder, linkage, and pin

# STANDARD / OPTIONAL

## STANDARD EQUIPMENT

### ISO Standard cabin

All-weather steel cab with 360° visibility

Safety glass windows

Rise-up type windshield wiper

Sliding fold-in front window

Sliding side window(LH)

Lockable door

Hot & cool box

Storage compartment & Ashtray

Radio & USB player

Cabin roof-steel cover

12 volt power outlet (24V DC to 12V DC converter)

### Computer aided power optimization (New CAPO) system

3-power mode, 2-work mode, User mode

Auto deceleration & one-touch deceleration system

Auto warm-up system

Auto overheat prevention system

### Automatic climate control

Air conditioner & heater

Defroster

### Self-diagnostics system

### Starting Aid (air grid heater) for cold weather

### Centralized monitoring

LCD display

Engine speed or Trip meter/Accel.

Clock

Gauges

Fuel level gauge

Engine coolant temperature gauge

Hyd. oil temperature gauge

### Warnings

Check engine

Overload

Communication error

Low battery

Air cleaner clogging

Indicators

Max power

Low speed/High speed

Fuel warmer

Auto idle

### Door and cab locks, one key

### Two outside rearview mirrors

### Fully adjustable suspension seat with seat belt

### Pilot-operated slidable joystick

### Four front working lights (2 boom mounted, 2 front frame mounted)

### Electric horn

### Batteries (2 x 12V x 160 AH)

### Battery master switch

### Removable clean-out dust net for cooler

### Automatic swing brake

### Removable reservoir tank

### Fuel pre-filter

### Boom holding system

### Arm holding system

### Track shoes (600mm)

### Track rail guard

### Accumulator for lowering work equipment

### Electric transducer

### Lower frame under cover (Normal)

## OPTIONAL EQUIPMENT

### Fuel filler pump (35 L/min)

### Beacon lamp

### Single-acting piping kit (breaker, etc.)

### Double-acting piping kit (clamshell, etc.)

### Quick coupler

### Travel alarm

### Booms

5.85 m

### Arms

2.1 m

2.5 m

3.05 m

3.6 m

### Cabin FOPS/FOG (ISO/DIS 10262-Level II)

FOPS (Falling Object Protective Structure)

FOG (Falling Object Guard)

### Cabin guard-front

Wire net

Fine net

### Cabin lights

### Cabin front window rain guard

### Sun visor

### Track shoes

Triple grousers shoe (700mm)

Triple grousers shoe (800mm)

Triple grousers shoe (900mm)

Double grousers shoe (700mm)

Full track rail guard (High walker only)

### Lower frame under cover (Additional)

### Pre-heating system, coolant

### Tool kit

### Operator suit

### Rearview camera

### Seat

Mechanical suspension seat with heater

### Hi-mate (Remote Management System)

### Fuel warmer

### Air compressor

### Rear work lamp

### Precleaner