

# SE400LCW 履带式液压挖掘机技术参数

## Hydraulic Crawler Excavator Technical Specifications

 <b>发动机 Engine</b>		 <b>行走系统 Travel System</b>	
型号 Model	WP10H	行走马达 Travel motors	GM70VA
形式 Type	电控高压共轨、水冷、直列六缸、涡轮增压	支重轮数量 Support roller quantities	9×2
		拖链轮数量 Carrier roller quantities	2×2
缸数 No. of cylinder	6	履带板数量 Travel shoes (260mm)	49×2
缸径×行程 Bore and stroke	116mm×150mm	行走速度 Travel speed	3.0/5.0km/h
排量 Displacement	9.5L	牵引力 Drawbar pulling force	315kN
额定功率 Power output	247kW/2000rpm	爬坡能力 Grade ability	70% (35°)
		离地间隙 Ground clearance	580mm
 <b>液压系统 Hydraulic System</b>		 <b>回转系统 Swing System</b>	
液压泵 Pump	HPR 210D	回转马达 Swing motor	柱塞马达
形式 Type	柱塞泵加齿轮泵 piston pump plus gear pump	回转马达型号 Swing motor type	GS23H
额定工作流量 Max. discharge flow	2X340L/min	回转速度 Swing speed	10.5r/min
主阀	OCV32		
 <b>挖掘力 Digging Force (ISO6015)</b>		 <b>润滑油及容量 Refilling Capacities &amp; lubrications</b>	
动臂长度 Boom length	6470mm	燃油箱容量 Fuel tank	620L
斗杆长度 Arm length	2812mm	冷却系统 Cooling system	35L
铲斗挖掘力 Bucket digging force	254kN	发动机机油量 Engine oil	30L
斗杆挖掘力 Arm digging force	210kN	液压油箱 Hydraulic oil tank	360L
		系统容量 Hydraulic System	420L
 <b>铲斗 Bucket</b>		 <b>操作重量和接地比压 Operating Weight and Ground Pressure</b>	
型式 Type	Backhoe bucket	履带板宽度 Shoe width	600mm
铲斗容量 Bucket capacity	1.95m <sup>3</sup>	接地比压 Ground pressure	70.5kPa
铲斗宽度 Bucket width	1671mm	操作重量 Operating weight	38700Kg

工作范围 Scope of work (mm)	
A	最大挖掘高度 Max. digging height 10160
B	最大卸载高度 Max. dumping height 6925
C	最大挖掘深度 Max. digging depth 7040
D	最大垂直挖掘深度 Max. vertical digging depth 5460
E	挖出 8 英尺水平面时的最大挖掘深度 Max. Depth cut for 2440m(8')Level Bottom 6855
F	最大挖掘距离 Max. digging distance 10855
G	地平面的最大挖掘距离 Max. digging radius at ground level 10650
H	工作装置最小回转半径 Min. swing radius of work equipment 4430

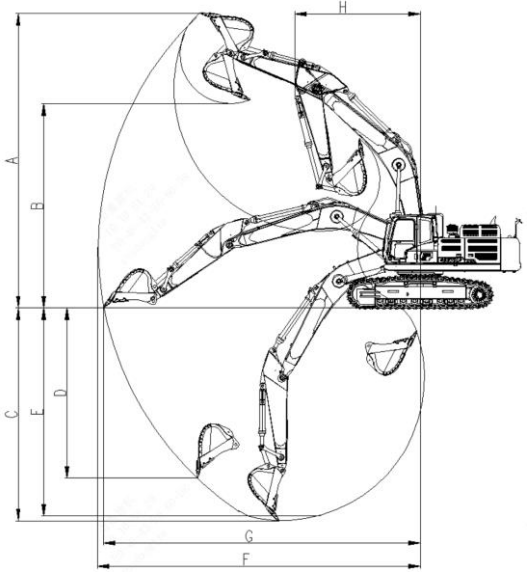

外形尺寸 Dimensions (mm)			
A	总长 Overall length 11265	I	轮距 Tread 4110
B	接地长度 (运输时) Ground contact length (Transportation) 6930	J	履带长度 Track length 5095
C	总高 (至动臂顶部) Overall height(to top of boom) 3800	K	轨距 Track gauge 2600
D	总宽 Overall width 3200	L	履带宽度 Track width 3200
E	总高 (至驾驶室顶部) Overall height(to top of cab) 3305	M	履带板宽度 Shoe width 600
F	配重离地间隙 Counter weight ground clearance 1350	O	机罩高度 Bonnet height 2920
G	最小离地间隙 Ground clearance 580	P	转台宽度 Revolving frame width 3190
H	尾部回转半径 Tail swing radius 3520	Q	回转中心至后端部距离 Distance from swivel center to tail 3465

