

SHANTUI

L98K-G

Wheel Loader



Engine model

Weichai WP13G375E470

Total power

276 kW /2,100 rpm

Operating weight

33,000 kg

Bucket capacity

5.6 m³

VALUE THAT WORKS

L98K-G TECHNICAL PARAMETERS

ENGINE

Emission standard	Stage IV
Brand	Weichai
Model	WP13G375E470
Rated power	276kW/2100rpm
Max. torque	1800N-m/1300~1500rpm
Displacement	12.54L
No. of cylinders	6
Exhaust mode	Turbocharging

PERFORMANCE OF LOADER

Rated load	23000kg
Max. breakout force	258kN
Unloading angle	45°
Unloading height	3410mm
Unloading distance	1350mm
Height of boom pin shaft	4695mm
Digging depth	100mm
Bucket capacity	5.6m ³
Operating weight	33000kg

TRANSMISSION SYSTEM

Transmission type	Electronic control fixed-axis gearbox
Torque converter	Single-stage, single-phase, 3-element
Max. travel speed (forward)	37.9km/h
Max. travel speed (backward)	26.5km/h
Forward gear	4
Reverse gear	3

DRIVE AXLE

Type of front axle differential lock	Hydraulically controlled differential lock
Type of rear axle differential lock	-
Swing angle of rear axle	±12°

STEERING SYSTEM

Type of steering system	Traffic amplification
Steering system pressure	21 Mpa

BRAKE SYSTEM

Service brake type	Dual-circuit full hydraulic wet brake
Service brake mode	-
Parking brake type	Hydraulic caliper disc brake
Parking brake mode	-

TIRE

Tire model	29.5-25
------------	---------

HYDRAULIC SYSTEM

Type of working pump	Variable displacement pumps
System pressure	26MPa
Boom lifting time	5.68S
Total cycle time	10.34S

OIL CAPACITY

Fuel tank	520L
Hydraulic oil tank	290L
Engine oil	24L
Drive axle (single side)	65L
Transmission	42L
Antifreeze	45L

OVERALL DIMENSIONS

A Vehicle length	9900mm
B Vehicle width	3570mm
C Vehicle height	3860mm
D Wheelbase	3800mm
E Wheel track	2420mm
F Min. ground clearance	428mm
G Steering angle	±40°
H Turning radius (outer side of front tire)	6830mm
I Turning radius (front tire center)	6430mm
J Turning radius (outer edge of bucket)	7774mm

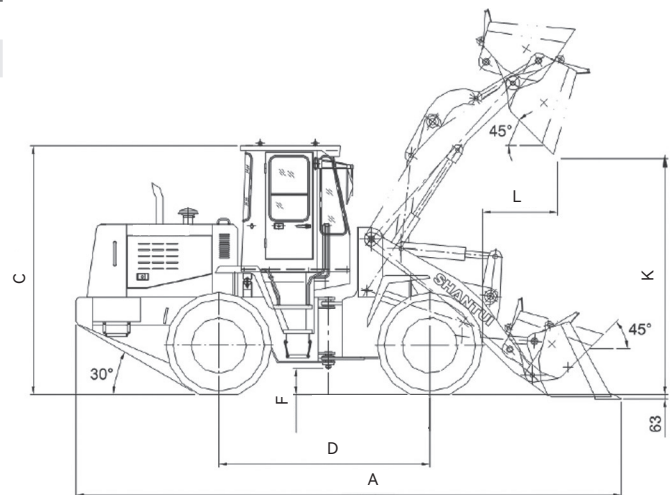
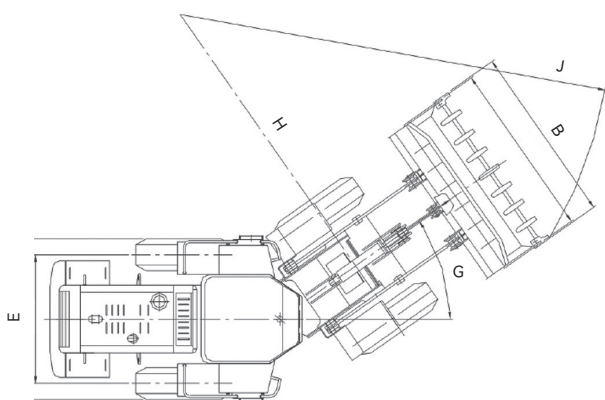

* THE SPECIFICATIONS ARE SUBJECT TO CHANGE WITHOUT NOTICE. THE PICTURES MAY INCLUDE OPTIONAL CONFIGURATION. THE ACTUAL COLOR & APPEARANCE OF THE PRODUCT MAY DIFFER FROM WHAT IS SHOWN.



Shantui Social

SHANTUI CONSTRUCTION MACHINERY CO., LTD.

ADD: NO. 58, G327 HIGHWAY, HI-TECH ZONE, JINING CITY, SHANDONG, CHINA

TEL: +86-537-2909369 FAX: +86-537-2311219

EMAIL: trade@shantui.com WEB: www.shantui.com

SHANTUI
VALUE THAT WORKS